

What Does it Mean to “Have Fiber” or Developing a Common Understanding and Terminology

Dale Smith
University of Oregon & NSRC
dsmith@uoregon.edu



UNIVERSITY OF OREGON



Why do we care about Fiber

- Fiber is the only way to go fast over distance
- E1 is not fiber. ADSL is not fiber.
- Fiber is required for land line services above multiple E1/ADSL.
- Wireless can provide capacity, but ultimately will be limited in distance and speed.
- We want to talk about fiber optic service to your campus from somewhere else.



Fiber Optic Services

- Service on fiber optic cabling provisioned and supported by provider
 - Buying or leasing “**Lit Services**”
- Fiber optic cabling owned by provider, but service provisioned by customer
 - Buying or leasing “**dark fiber**”
- Fiber optic cabling owned and services provisioned by customer – no provider
 - Owning “**dark fiber**”



Dark Fiber Pro and Con

- Dark fiber disadvantages
 - You have to worry about what equipment to buy and install
 - Who do you call when a link goes down?
- Dark fiber advantages
 - Not bandwidth limited
 - Recurring costs don't increase with speed
- Nothing wrong with buying “lit” services if the price is right



Introduction to Fiber Technology

- Two basic types of fiber
 - Multi Mode limited to 2km @ 100Mbps
 - Single Mode 70km @ virtually unlimited
- Multiple types of single mode
 - Optimized for 1310 and 1550 nm operation
 - Optimized for WDM operation
- For wide area networking, we are always talking about single mode fiber



Going Fast on Fiber

- Multi mode Fiber
 - 62.5 micron
 - 1Gbs to 500m
 - 10Gbs to 220m
 - 50 micron laser optimized
 - 1Gbs to 500m
 - 10Gbs to 300m
- Single mode Fiber
 - 1Gbs to 70km
 - 10Gbs to 70km



How About Going Even Faster?

- 100 Gigabits?
- Dispersion becomes your enemy
- Even single mode fiber has dispersion
 - Chromatic Dispersion (CD) Even slightly different colors of light travel different speeds
 - Polarization Mode Dispersion (PMD) Slight variations from true roundness causes differently polarized light to travel different distances.



The Solution Today is WDM

- Wave Division Multiplexing (WDM)
 - Provisioning multiple Gigabit or 10 Gigabit using different colors of light
 - Coarse (CWDM)
 - Fewer waves, low cost
 - 1310nm frequency spectrum
 - Not suitable for amplification – short haul (70km)
 - Dense (DWDM) more waves
 - More waves, higher cost
 - 1550nm frequency spectrum
 - Suitable for EDFA amplification – long haul (1000s of km)



WDM Simple Single Span

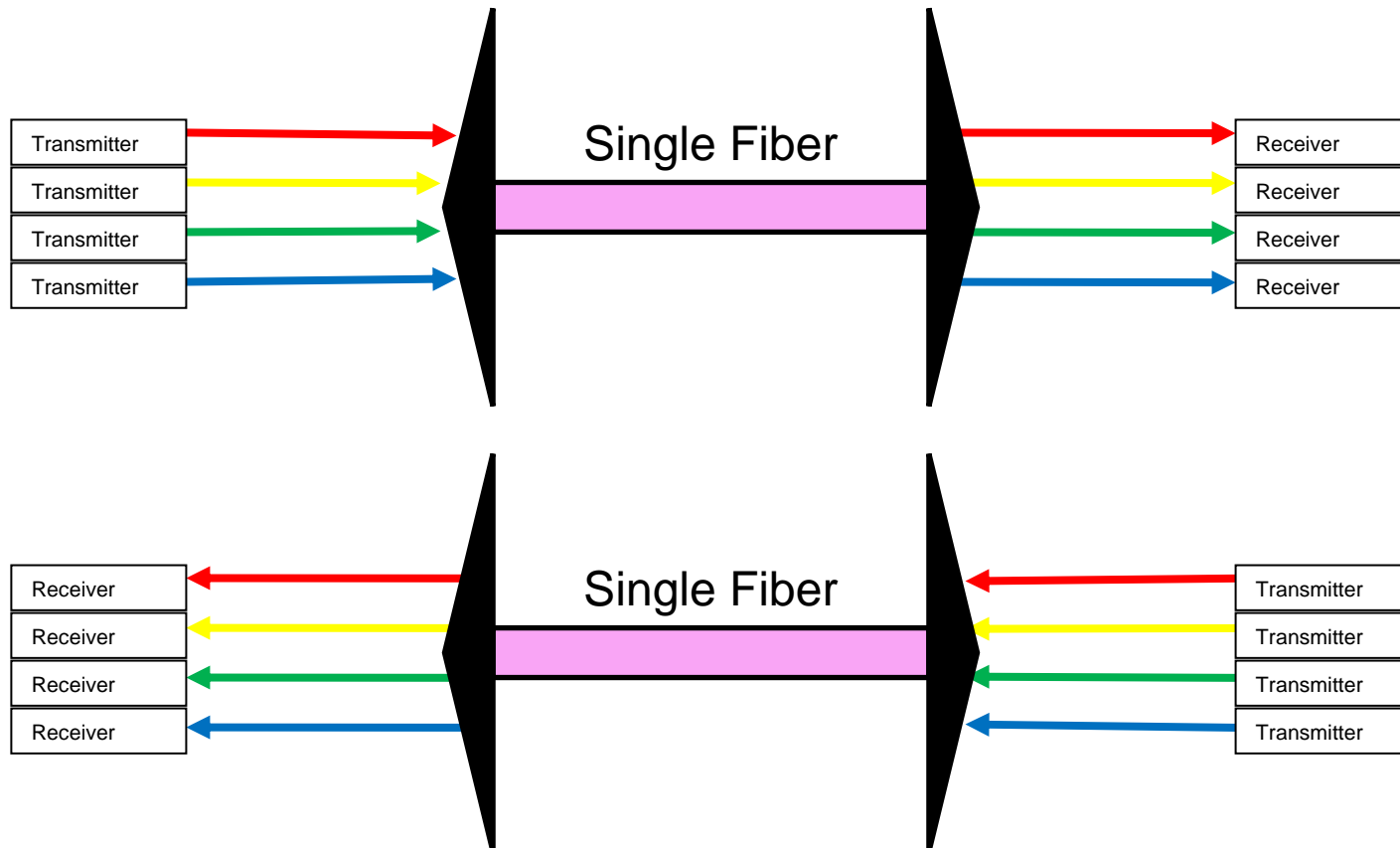

Optical Add Drop Multiplexor

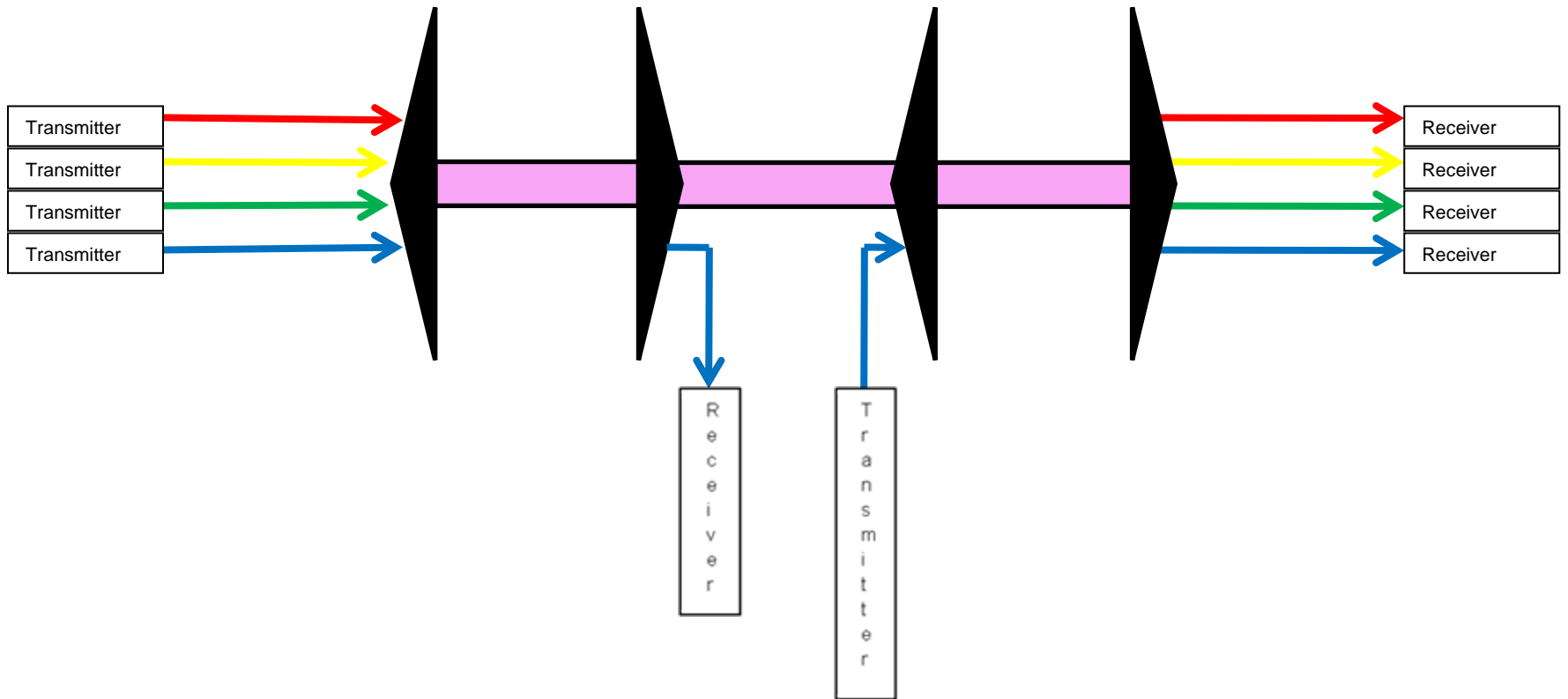

Can Build Complex Networks

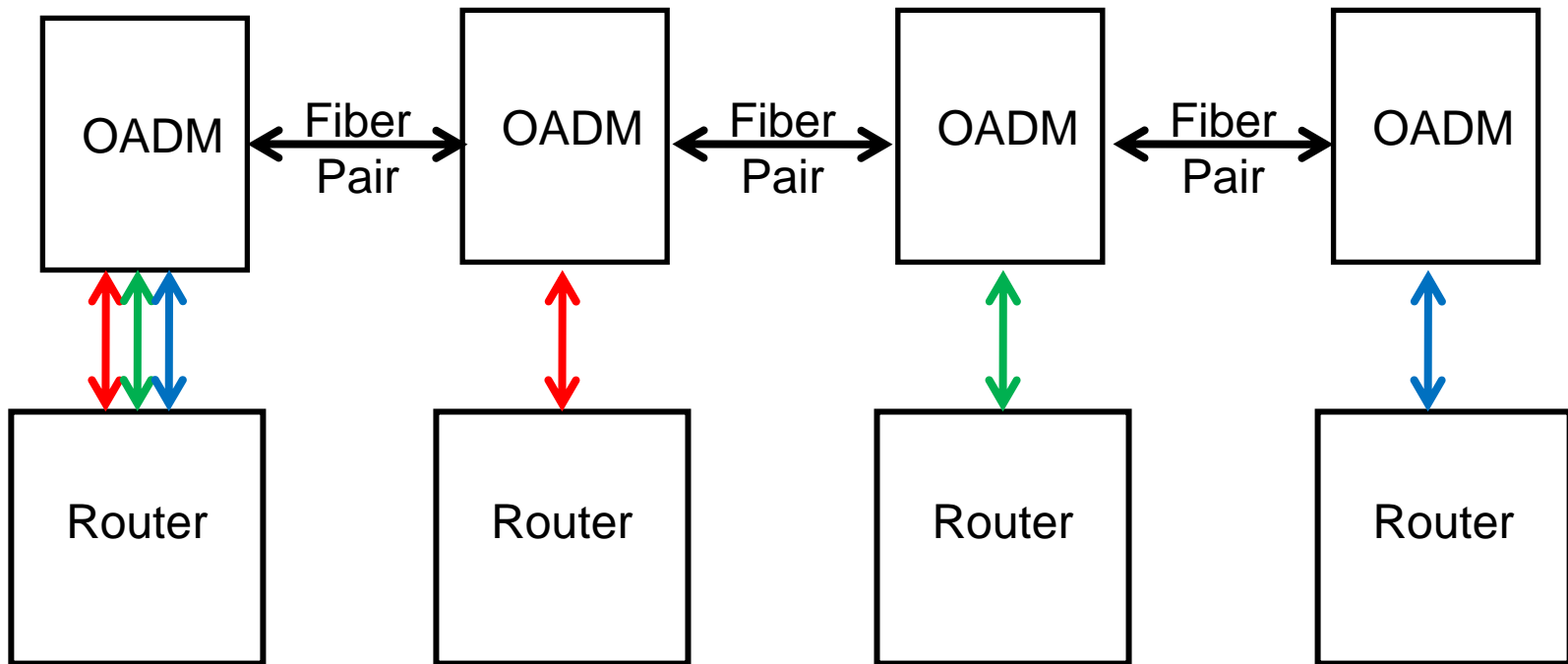

Different Internet Service Models

- Internet Service Provider (ISP) provides Internet and circuit to your site
- ISP is different from provider of circuits
- Best situation when you have choices in both ISP and provider of telecom or fiber services
 - Competition is the key



Try to Reduce Cost

- These tricks work only if the legal and regulatory environment is favorable
 - Look for dark or low cost lit fiber between institutions
 - Aggregate demand and get a single ISP connection
 - Get dark or low cost lit fiber to ISP to avoid local loop costs



Example

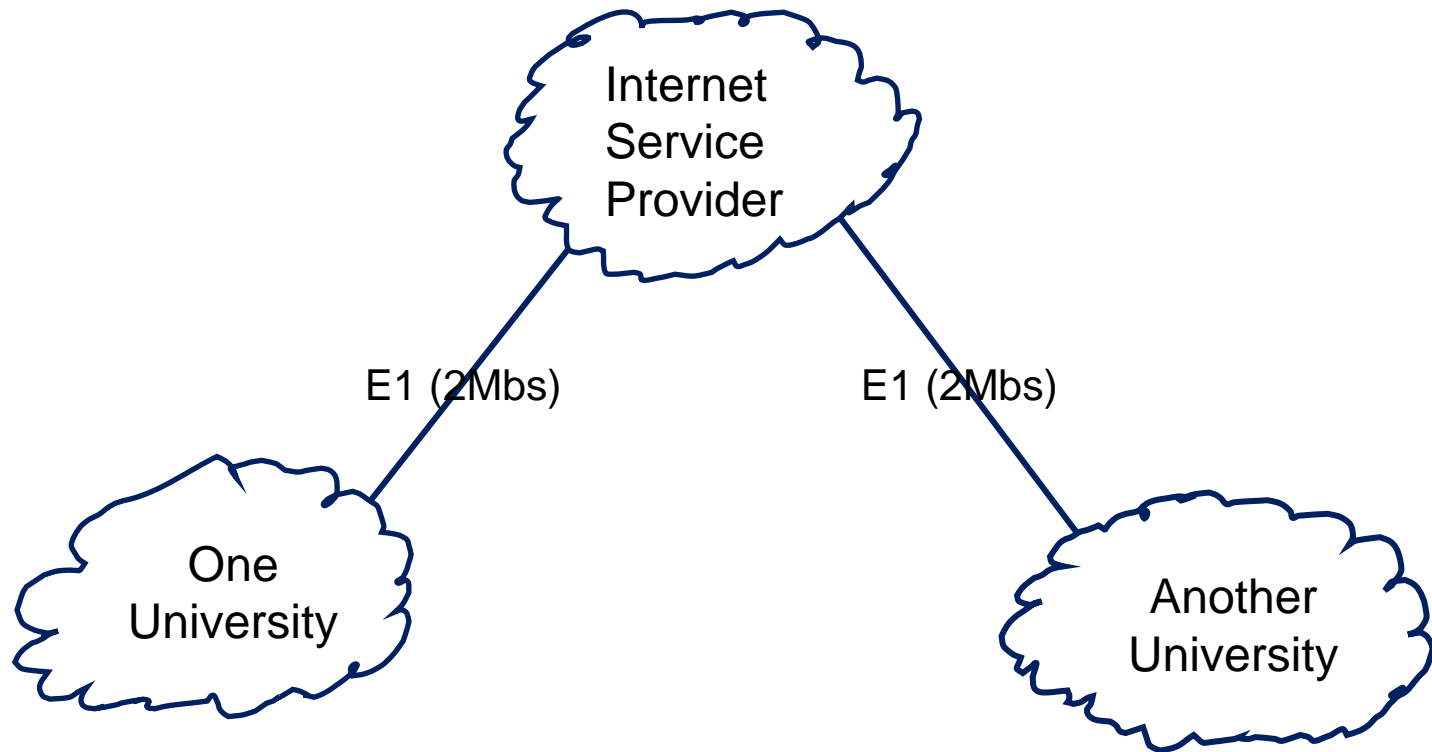

Example

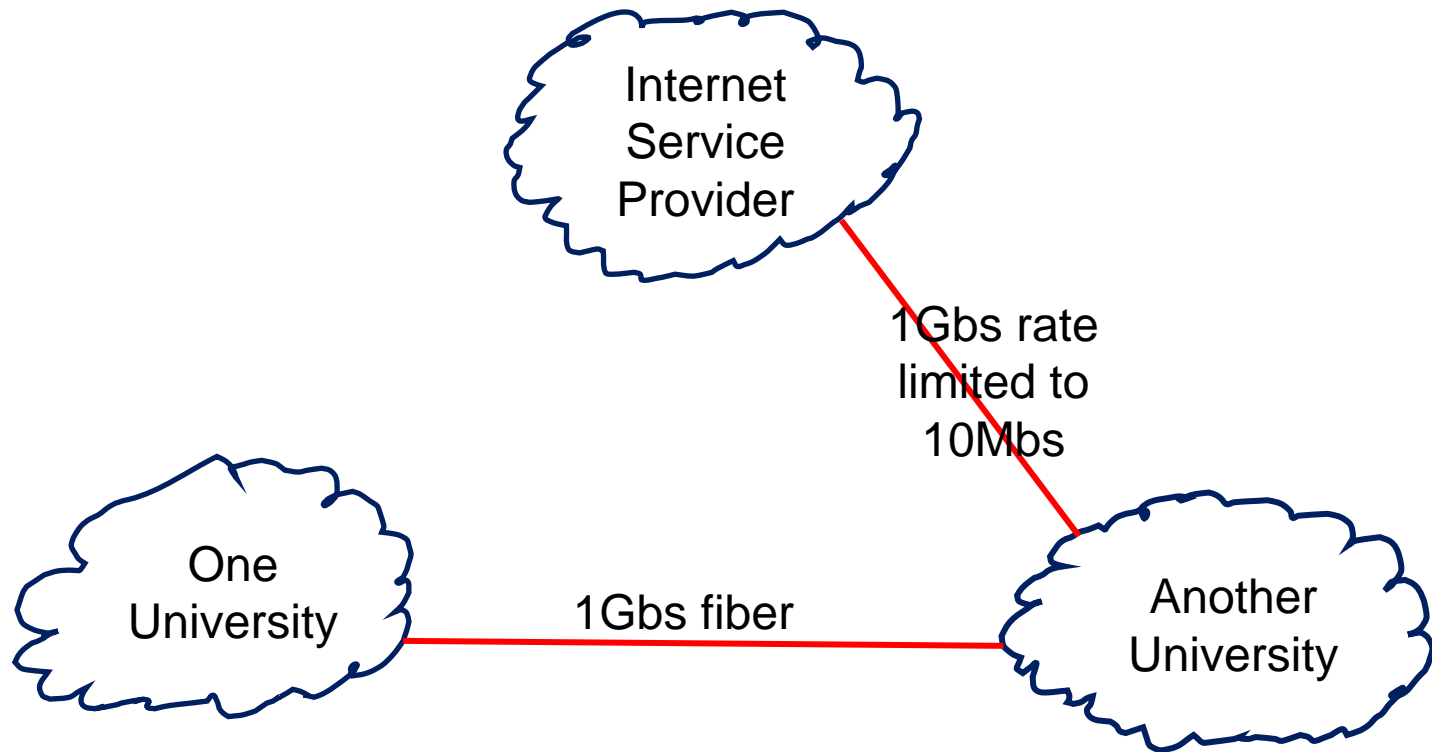

How to Get Access to Fiber

- Legal and Regulatory Issues
- Incumbent Telephone Company may not be your only source
 - Competitive cellular phone companies
 - Power company
 - The city owns the right of way and has needs
- Get to know telecom engineers and city and government right of way and telecom people
- Be creative



Parting Thoughts

- Getting access to fiber, both dark and lit takes time.
- Be patient, be creative.
- Remember, campus network is the foundation
 - Without a strong foundation, any REN will fail
 - Work on improving your campus network
 - Day long workshop on campus networking tomorrow

